



Wet Armature Solenoid Operated Directional Control Valves

DG4S*-01, 60 design

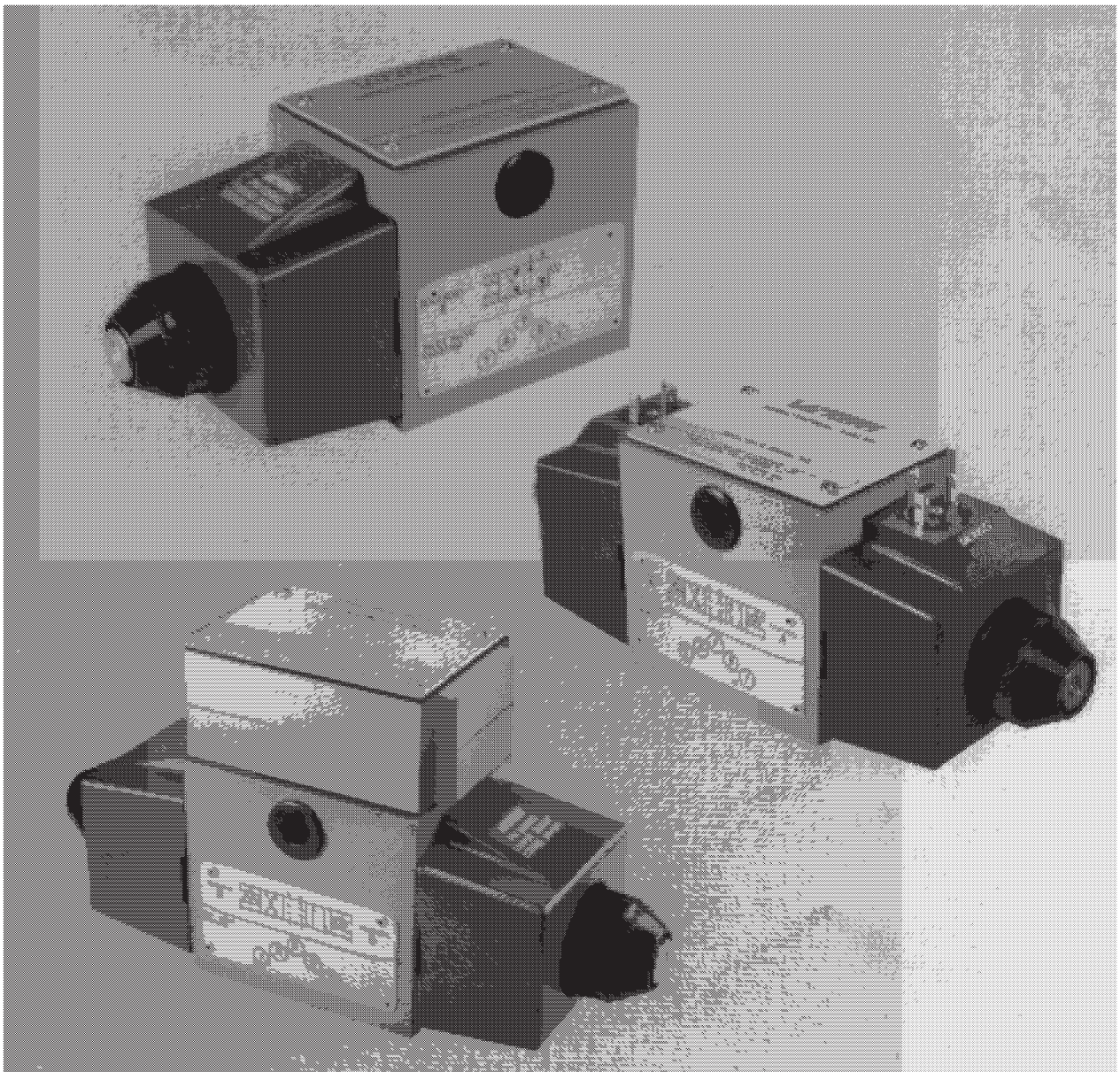

Table of Contents

Basic Characteristics	3
Functional Symbols	3
Model Code	4
Maximum Pressure	4
Solenoids	4
Pressure Drop	5
Maximum Flow	6
Installation Dimensions	7
DG4S2-012A-*60	
DG4S4-01*A-*60	
DG4S4-01*B-*60	
DG4S4-01*F-*60	
DG4S4-01*C-*60	
DG4S4-01*N-*60	
DG4S2-01*N-*60	
Installation Dimensions	8
SDG4S4-01*A-*60	
Installation Dimensions	9
PBDG4S*-01**-*60	
Installation Dimensions	10
PA*DG4S*-01**-*60	
PA5DG4S*-01**-*60	
SPA5DG4S*-01**-*60	
Installation Dimensions	11
W, WT & WL Models	
Installation Dimensions	12
U Models	
Mounting Subplates and Bolt Kits	13

Basic characteristics

Max. pressure	Up to 250 bar (3600 psi) dependent on fluid
Max. flow rates	Up to 95 l/min (25 USgpm) dependent on spool
Mounting pattern	ISO 4401-05/ CETOP 5/NFPA-D05

General description

DG4S* models are direct solenoid operated, 2-way or 4-way directional control valves. Their primary function in a hydraulic circuit is to direct fluid flow to a work cylinder or to control the direction of rotation of a hydraulic motor.

Port connections are made by mounting the valve on a manifold or subplate containing the interface.

Valves are available with AC or DC wet-armature solenoid(s). Electrical connections to the valve are made in an electrical wiring housing or by various plug-in devices. A ground terminal is provided.

Functional symbols

Standard Spool Types	Graphic Symbol Center Condition	"A" Models ▲ Spring Offset	"B" Models ▲ Spring Centered	"C" Models Spring Centered	"F" Models ▲ Spring Offset	"N" Models Detented (No Spring)
0						
1						
11						
2						
3						
31						
6						
7						
8						
33						
2 (2-way)						

▲ Standard (right hand) build shown.
"A" solenoid omitted.

Note

On all models, when solenoid "a" is energized, flow is always "P" to "A". When solenoid "b" is energized, flow is always "P" to "B". This is in accordance with the ANSI-B93.9 standard. Solenoid designations "a" and "b" are identified on the diagram plate on the side of the valve.

Model Code

(F3) - * *** DG4S * ** - 01 * ** - (U) - ** - 60 - (LH)

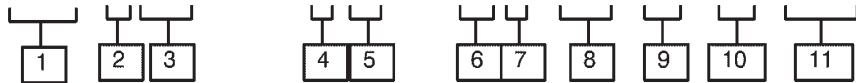

1 Seals

Blank – Standard seals
F3 – Special seals

2 Monitor switch

S – Monitor switch (Available as “A” spring offset model only)
Omit if not required.

3 Electrical plug options

PA – Insta–plug (male only)
PB – Insta–plug male & female receptacles
PA3 – 3 pin connector
PA5 – 5 pin connector
Omit if not required.

4 Flow direction

2 – 2 way
4 – 4 way

5 Electrical accessories

L – Solenoid indicator lights
W – Wiring housing
LW – Wiring housing with indicator lights
WT – Wiring housing with terminal strip
Omit if not required.

6 Spool types

See “Functional symbols” section.

7 Spool/spring arrangement

A – Spring offset, P to A
B – Spring centered, solenoid “a” removed
C – Spring centered, three position
F – Spring offset, P to A; shift to center
N – No spring, detented

8 Wet armature solenoid(s)

(Non–serviceable core tubes)
Blank – Flying lead coil(s)
U – DIN 43650 coil(s) without electrical plug

9 Coil identification letter(s)

See “Solenoids” section.

10 Design number

Subject to change.
Installation dimensions remain as shown for designs 60 through 69.

11 Left hand assembly

Omit for right hand assembly with solenoid “a” removed.

For DIN 46350 electrical plug(s)

See “U models” in “Installation dimensions” section.

For mounting subplates and bolt kits

See “Installation dimensions” and “Ordering procedure” sections.

Maximum pressure

Ports P, A & B 250 bar (3600 psi)*
Port T 70 bar (1000 psi)

*70 bar (1000 psi) with high water base fluids (95% maximum water content)

Solenoid energizing

Spring centered and spring offset valves will be spring positioned unless the solenoid is energized continuously. No–spring detented valves may be energized momentarily, approximately .15 second; when the solenoid is de–energized the spool will remain in the last position attained, provided there is no shock, vibration or unusual pressure transients.

NOTE

Any sliding spool valve, if held shifted under pressure for long periods, may stick and not spring return, due to silting. Therefore, it is recommended that the valve be cycled periodically to prevent this from occurring.

Solenoids

Solenoid Identification Letter	Solenoid Voltage Rating	Inrush Amps (rms)	Holding Amps (rms)	Holding Watts	
B	120 VAC 60 Hz	3.80	0.69	35	
	110 VAC 50 Hz	4.10	0.85	33	
D	240 VAC 60 Hz	2.10	0.34	36	
	220 VAC 50 Hz	2.30	0.45	34	
ED	240 VAC 50 Hz	1.85	0.27	28	
A	110 VAC 50 Hz	3.80	0.63	29	
C	220 VAC 50 Hz	2.00	0.30	28	
G	12 VDC	—	3.67	44	
H	24 VDC		1.83	44	
J	48 VDC		0.92	44	
X	250 VDC		0.17	44	
DP	125 VDC		—	0.35	44
				—	—

Response time

The following response times were measured from the point of energization/ de–energization to the point of first indication of inlet pressure change.

Response up to full system pressure is dependent on the system’s compressed volume and can vary with each application.

Model	Valve type	AC Solenoid		DC Solenoid	
		Shift	Return	Shift	Return
B/C	Spring centered	20 ms	40 ms	50 ms	80 ms
A	Spring offset	18 ms	25 ms	50 ms	60 ms
F	Spring offset	18 ms	18 ms	30 ms	80 ms
N	Detented	25 ms	—	60 ms	—

Drain

On 2-way valves, "T" is the drain and must be connected to the tank through a surge-free line, so there will be no back pressure at this port.

NOTE

Surges of oil in a common line serving these and other valves can be of sufficient magnitude to cause inadvertent shifting of these valves. This is particularly critical in the no-spring detented type valves. Separate tank lines, or a vented manifold with a continuous downward path to tank, are necessary.

Pressure drops

The pressure drop curves give approximate pressure drop (ΔP) when passing 21 cSt (100 SUS) fluid (having .865 specific gravity) through the indicated flow path.

Pressure drop curve reference chart

Spool type	Curve numbers				
	P-A	B-T	P-BA-T	P-T	
0C/N	2	1	3	1	2
1C	1	2	3	1	-
11C	2	1	2	2	-
2C/N	2	2	3	2	-
3C	3	2	3	1	-
31C	3	1	3	2	-
6C/N	4	1	4	1	-
7C/N	1	2	1	2	-
8C	3	4	3	4	6
33C/N	3	2	3	2	-
2 way					
2A		2	-	7	-
2A-LH		7	-	2	-
2N		2	-	2	-

Pressure drop curve reference chart

Spool type	Curve numbers			
	P-A	B-T	P-B	A-T
0A/F	1	2	2	2
0A/F-LH	2	2	2	2
1F	1	2	-	-
1F-LH	-	-	2	2
2A/F	2	2	5	4
2A/F-LH	4	4	3	2
3F	2	1	-	-
3F-LH	-	-	2	2
6A/F	2	1	6	3
6A/F-LH	4	2	3	2
7A/F	1	2	2	4
7A/F-LH	2	3	2	2

For any other viscosity, the pressure drop (ΔP) will change as follows:

Viscosity cSt (SUS)	14 (75)	32 (150)	43 (200)	54 (250)	65 (300)	76 (350)	86 (400)
% of ΔP (Approx)	93	111	119	126	132	137	141

For any other specific gravity (G_1), the pressure drop (ΔP_1) will be approximately: $\Delta P_1 = \Delta P (G_1/G)$

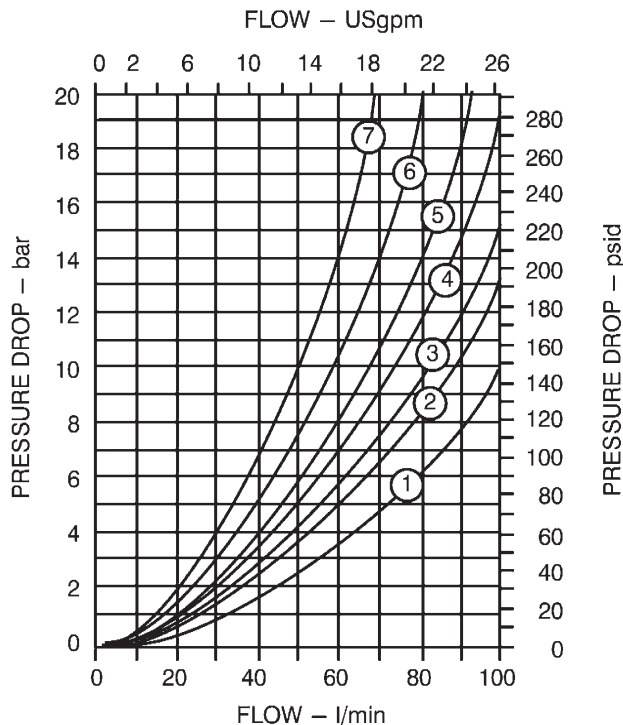

Maximum flow data

Maximum recommended flow data is for AC or DC solenoids at 90% nominal voltage in a 4-way circuit with cylinder ports either looped or blocked and containing 2,5 liter (.66 USgpm) compressed volume. Reduced performance may result when certain spools are used in 3-way circuits.

Maximum flow chart reference

Model	Spool type	Curve number	
		AC	DC
A	0	1	1
	2	2	2
	6	3	3
	7	2	2
B/C	0	1	1
	1	6	6
	11	6	6
	2	1	1
	3	2	2
	31	2	2
	6	2	2
	7	1	1
	8	4	8
	33	1	1
F	0	1	1
	1	5	5
	2	1	1
	3	1	7
	6	1	7
N	0	1	1
	2	1	1
	6	1	1
	7	2	2
	33	1	1
2-way			
A	2	5	5
N	2	3	3

AC & DC solenoid valves

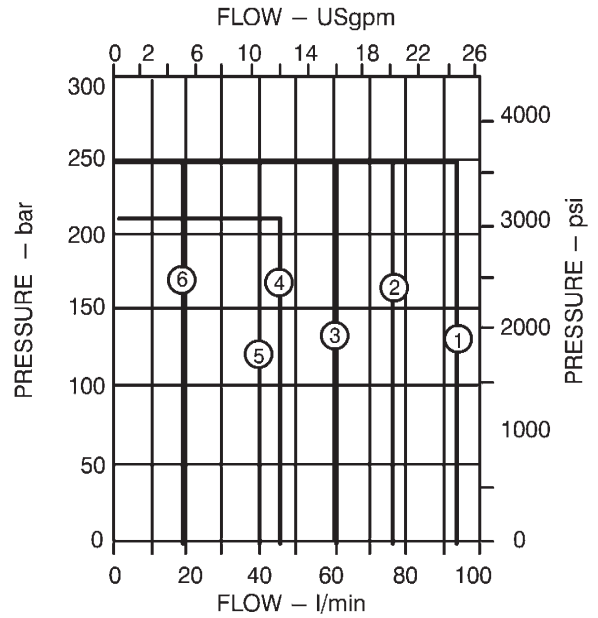

AC & DC solenoid valves

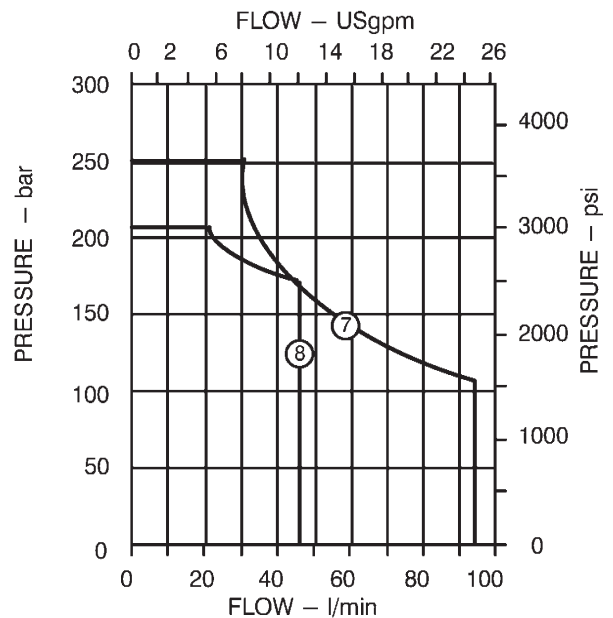

Seals/fluids

Special F3 seals are required for use with phosphate ester type fluids or their blends. Standard seals are suitable for use with water glycol, water-in-oil emulsion fluids, HWBF (95% maximum water content), and petroleum oil.

Application recommendations

Filtration.....ISO 4406 Code 18/15
 Operating temp.....20° to 50°C (70° to 120°F)
 Fluid viscosity.....16 – 51 cSt (75–250 SUS)

Installation dimensions in mm (inches)

Applicable models

- DG4S2-012A-*--60 Spring offset
- DG4S4-01*A-*--60 Spring offset
- DG4S4-01*B-*--60 Spring centered
- DG4S4-01*F-*--60 Spring offset

Right hand model shown ●

3rd angle projection

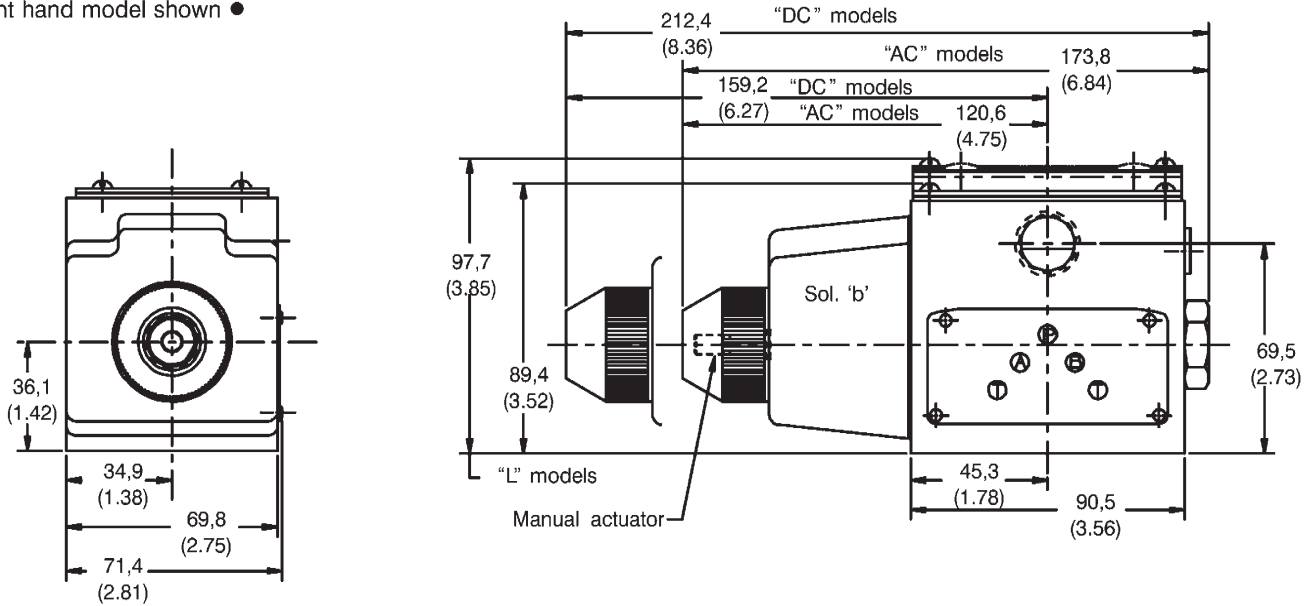
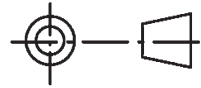

- "8B" right hand build model has solenoid 'b' on opposite end ("B" port end).

Applicable models

- DG4S4-01*C-*--60 Spring centered ●
- DG4S4-01*N-*--60 No spring detented
- DG4S2-01*N-*--60 No spring detented

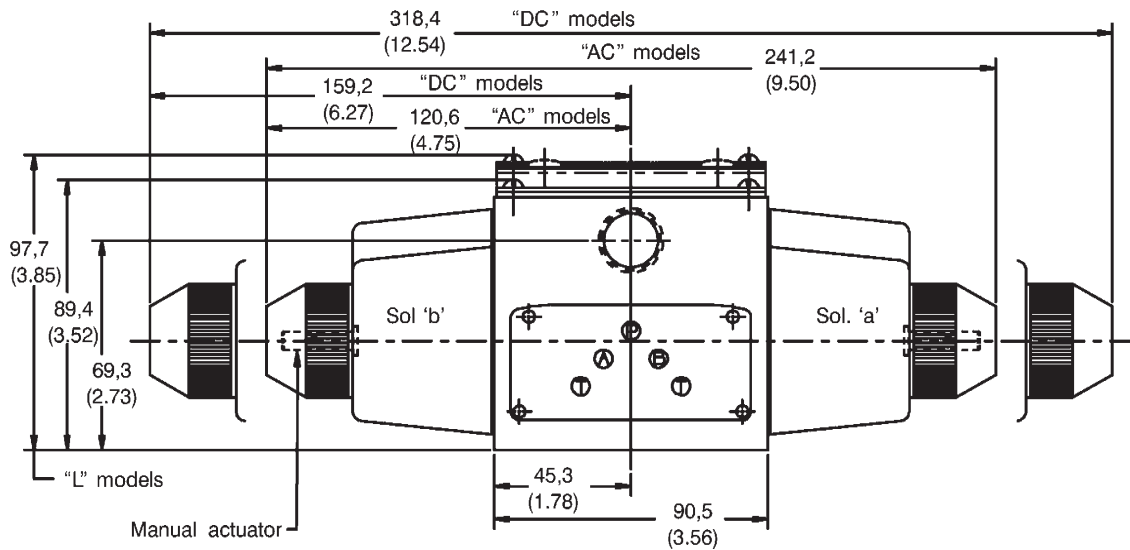

- "8C" models have solenoid designations reversed.

Applicable models

PBDG4S*-01 *-*-60

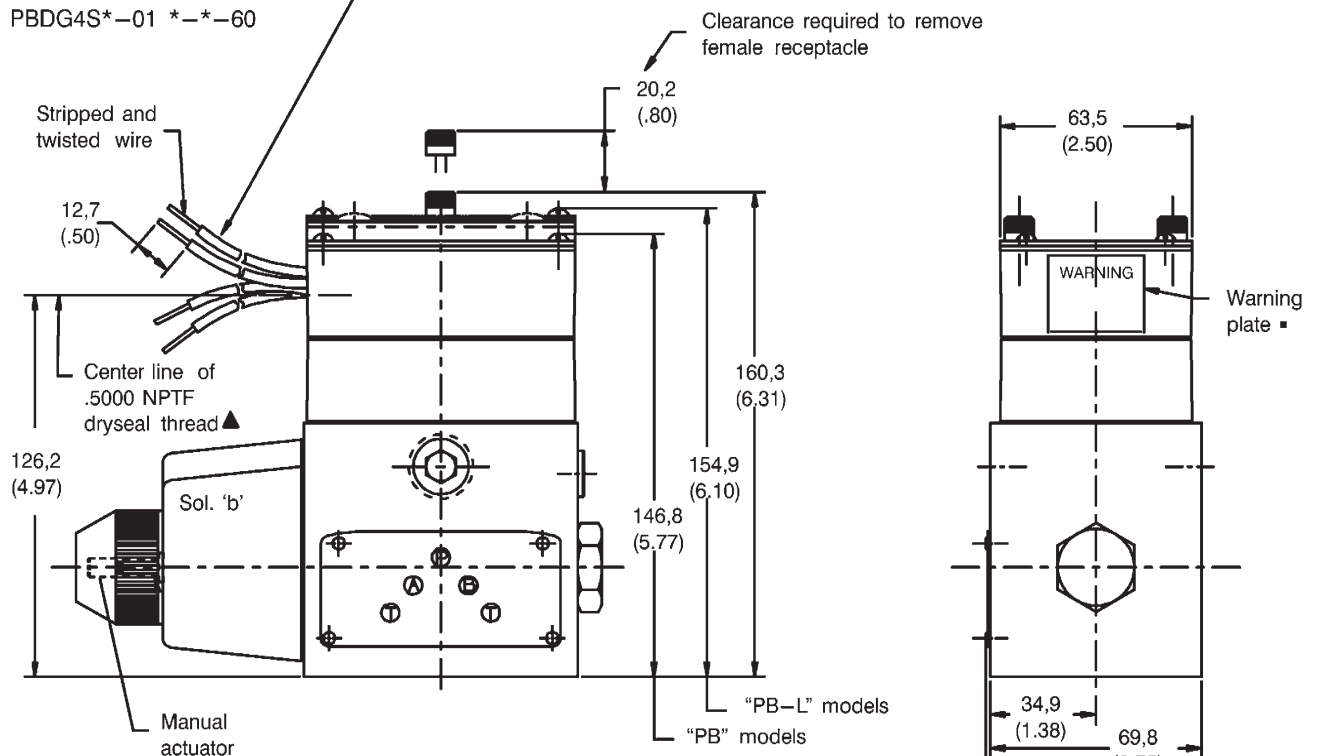

4 leads approx. 178 mm (7.00") long. White leads are connected to solenoid 'a' and black leads are connected to solenoid 'b'. (See diagram plate) For type "8" spool and left hand models, conduit connection location is reversed.

▲ Electrical conduit connection is over solenoid on single solenoid models, and over "b" solenoid on dual solenoid models. See diagram plate for "b" solenoid location.

Warning

Electrical power must be disconnected before removing or replacing this receptacle.

The "insta-plug" consists of the following features:

1. Section "A", a four-pronged self aligning electrical plug secured in a housing that is mounted on top center of the valve body where the solenoid leads terminate; or:
2. A "B" complete insta-plug assembly that includes the "A" housing on top of which rests a similar housing containing the mating receptacle. The two housings are keyed to assure proper hook-up.

The top housing is removed from the lower ("A") housing to break the electrical connections to the valve solenoids, or pressed onto the "A" housing to complete the circuit. The assembly is held together by two slotted thumb screws.

Solenoids "A" and "B" are identified on the plug-in and receptacle housings; they correspond with solenoid identification plate.

Connections to the electric power are made through the end of the receptacle housing and can be prewired by the customer. End location of electrical conduit port permits space-saving side-by-side valve mounting.

Wire leads approximately 177.8 mm (7.00") long are provided when no lights are specified. Models with lights have terminals inside the receptacle housing.

A nameplate and solenoid indicator lights are part of the receptacle when specified.

After initial installation, electrical and hydraulic connections need not be disturbed when valve with insta-plug is removed.

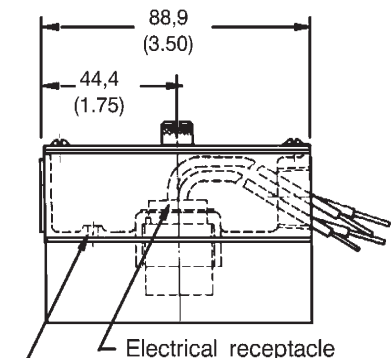

Electrical receptacle

8-32 Tapped hole for customer to connect ground

Solenoid indicator lights

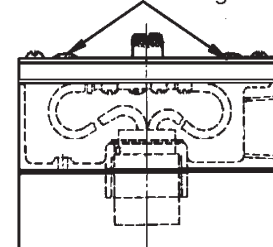

Applicable models

- PA*DG4S*W/LW-01*A-*--60
- PA*DG4S*W/LW-01*B-*--60
- PA*DG4S*W/LW-01*F-*--60
- PA5DG4S4W/LW-01*C-*--60
- PA5DG4S4W/LW-01*N-*--60
- SPA5DG4S4W/LW-01*A-*--60

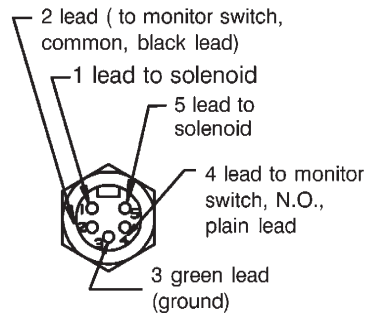
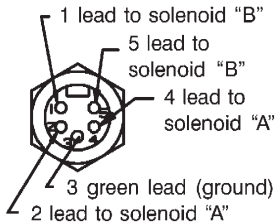
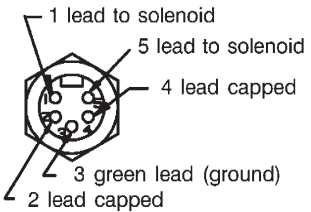
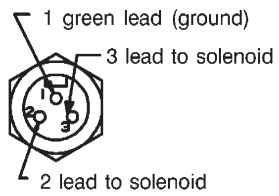
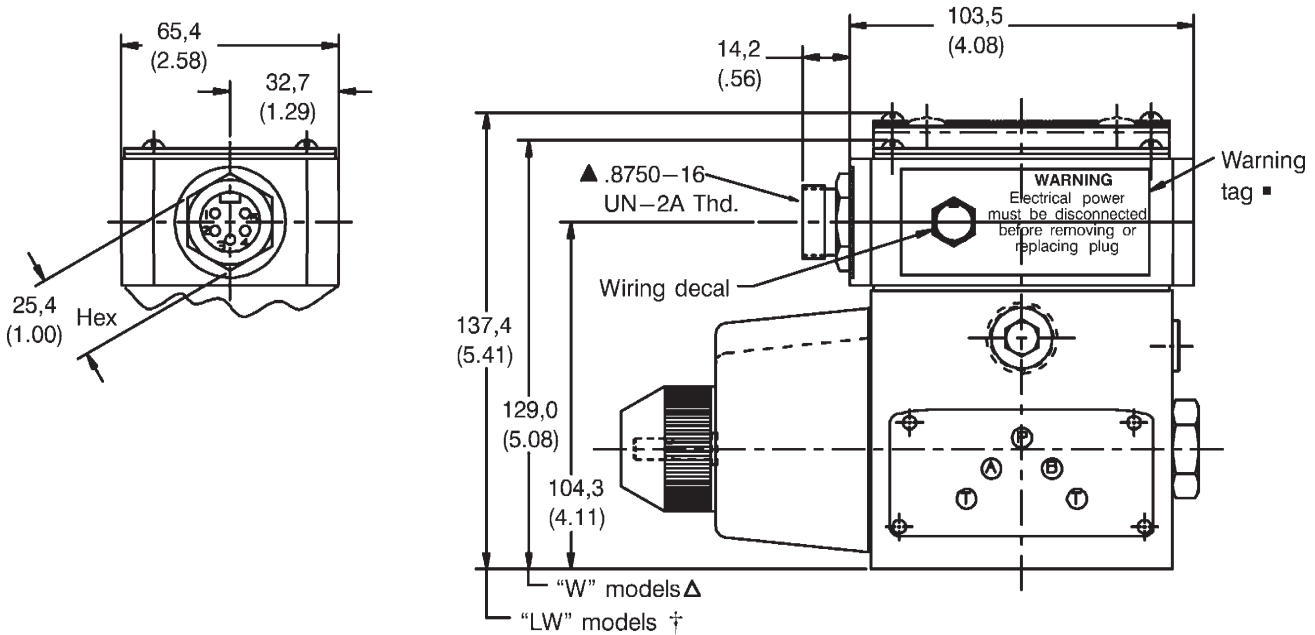

PA3DG4S*W/LW-01-*--60**

A models
B models
F models

PA5DG4S*W/LW-01-*--60**

A models
B models
F models

PA5DG4S4W/LW-01-*--60**

C models
N models

SPA5DG4S4W/LW-01-*--60**

A models only

▲ Electrical connection is over solenoid on single solenoid models, and over "b" solenoid on dual solenoid models. See diagram plate for "b" solenoid location.

† Receptacle will be prewired directly to the terminals on the solenoid indicator light package. (For exception see note "●").

● For models with monitor switch, wires to be supplied and connected by customer.

Electrical rating 600 volts, 3 pole, 10 amps and 5 pole, 8 amps. The female portable plug to be furnished by customer.

▲ Receptacle will be prewired to the solenoid eyelets. The connection will be made via No. 6 screws and nuts insulated with black electrical tape. (For exception see note "●").

■ **Warning**
Electrical power must be disconnected before removing or replacing this receptacle.

W, WT & LW models

● For models with monitor switch, wires to be supplied and connected by customer.

The housing can be rotated 180° if the connection is required on the opposite end. This connection will readily accept common electrical quick disconnect assemblies on the market. The wiring housing is available with all options.

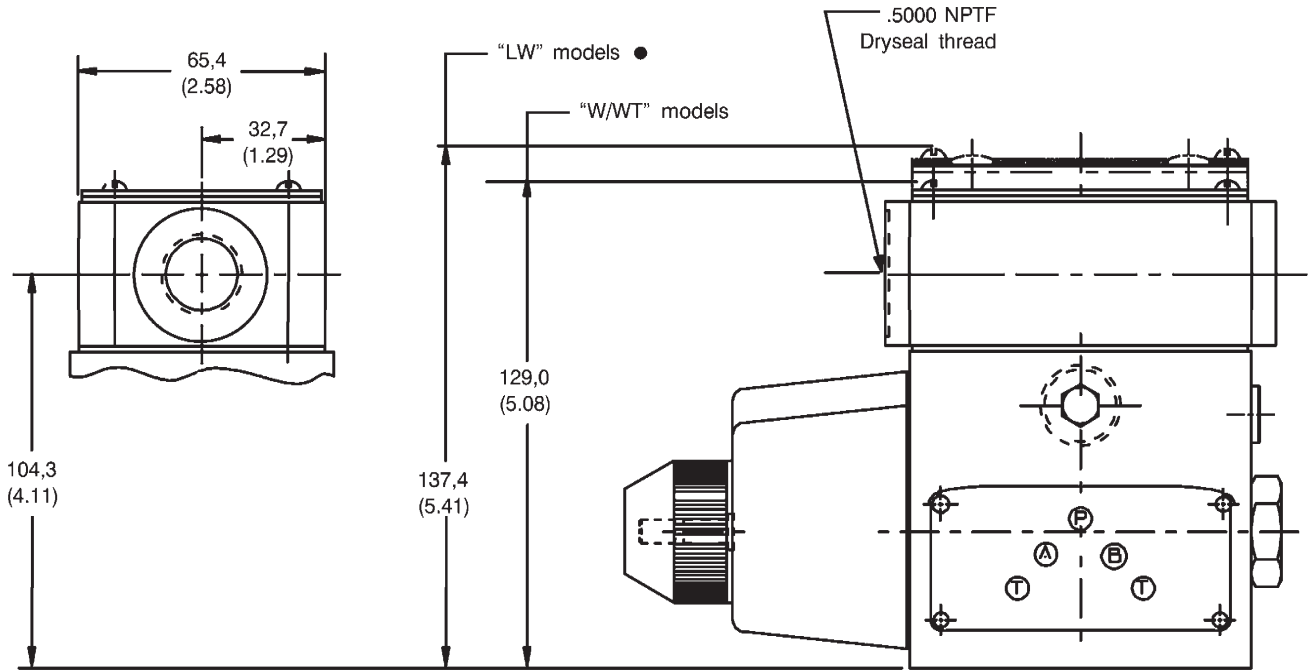

DG4S*–W–01

A drilled hole is provided for a customer's no. 8 self tapping screw which will permit a ground wire to be secured to the pilot valve body. (Not shown on this drawing). The wiring housing has a cast hole ③ which also permits securing a ground wire with customer's no. 8 self tapping screw. Units can be series grounded if desired. The DG4S*–01 pilot valve bodies have a cast "ground symbol" adjacent to the drilled hole.

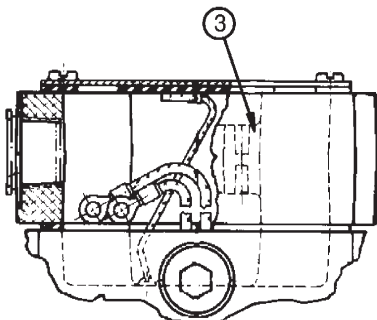

DG4S*–LW–01

Lights are "on" when there is voltage across the solenoids.

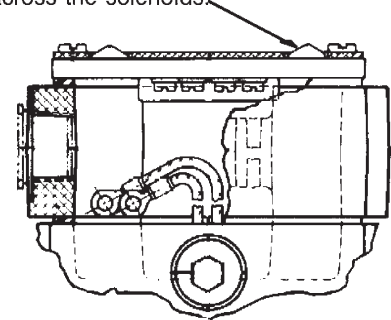

U models

▲ This interface is used for connecting electrical receptacles conforming to German DIN std 43650.

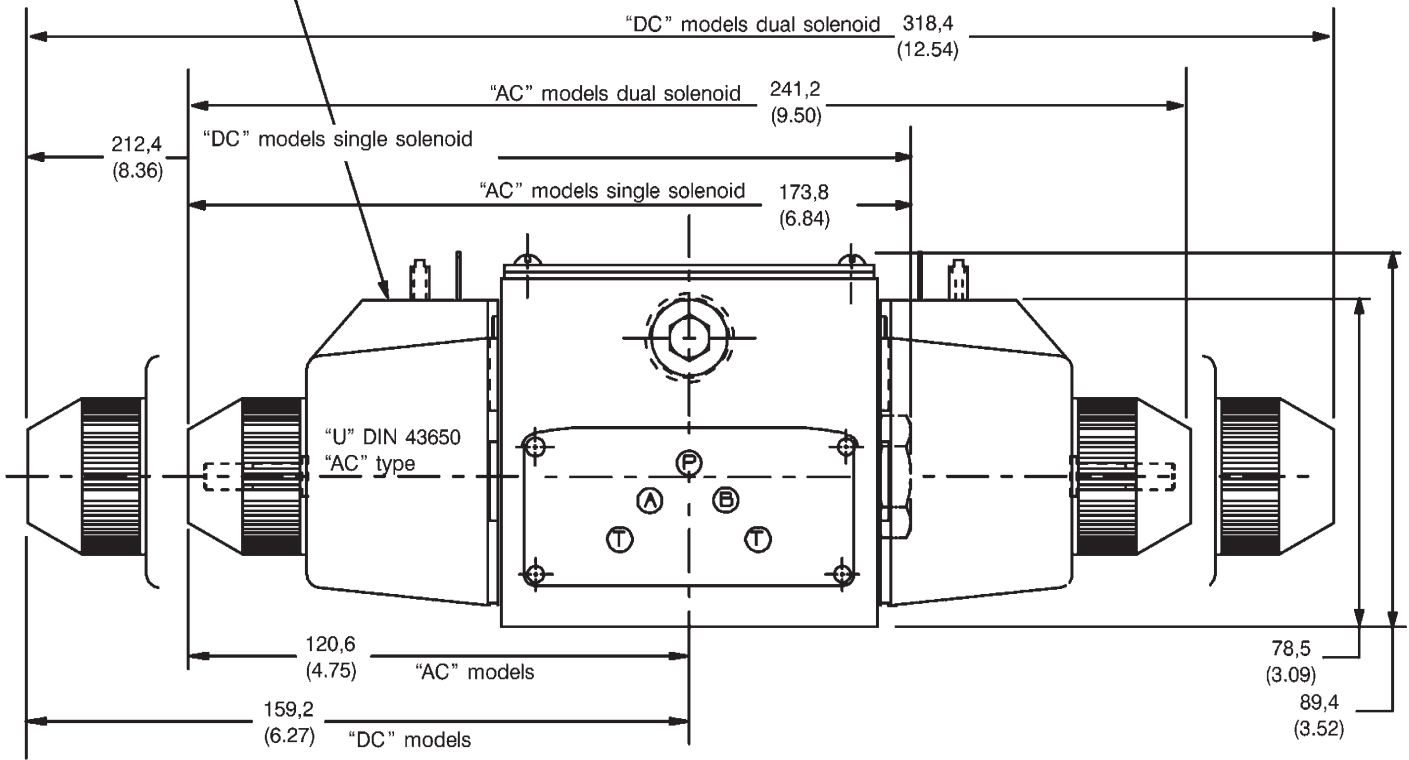

▲ Plug connector

(Order separately)
(ISO4400/DIN 43650)

Cable diameter range Ø6–10mm (0.24–0.40)
 Wire section range Ø,5–1,5mm² (0.0008–0.0023in²)
 Terminals Screw type
 Type of protection IEC144 class IP65, when plugs are fitted correctly to the valves with the interface seals (supplied with plugs) in place.

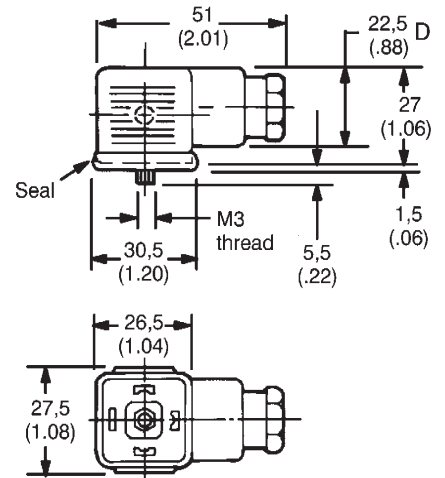

Connector can be positioned at 90° intervals on valve by re-assembling contact holder into appropriate position inside connector housing.

Connectors with and without indicator lights are available (Order separately):

Receptacle	Voltage (AC or DC)	Gray – "A" sol.	Black – "B" sol.
Without lights	—	710776	710775
With lights	12–24	977467	977466
	100–125	977469	977468
	200–240	977471	977470

Mounting Subplates and Bolt Kits

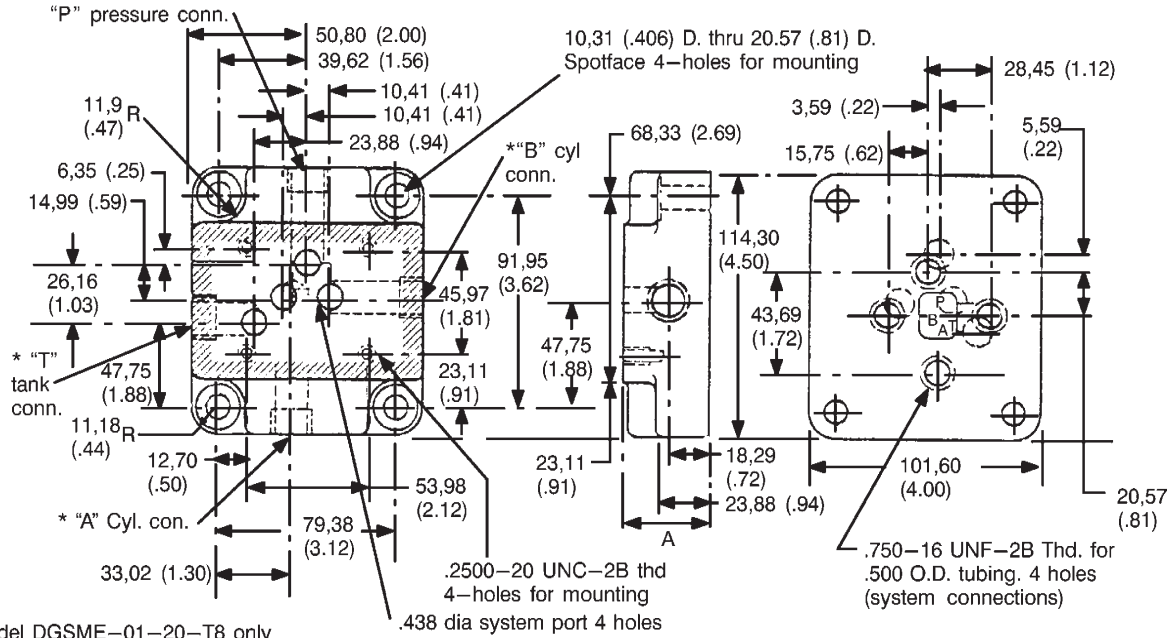

*Ports on model DGSME-01-20-T8 only

Model	Dimension "A"
DGSM-01-20-T8	31,75 (1.25)
DGSME-01-20-T8	38,10 (1.50)

When subplate is not used, a machined pad (as indicated by subplate shaded area) must be provided for mounting; pad must be flat within 0.0127 mm (.0005 inch) and smooth within 1.6 µm (63 microinch).

Mounting position

The mounting position is unrestricted for all valves, except detented (N model) valves which must be installed with their longitudinal axis horizontal for reliable operation.

Ordering procedure

Valves, subplates and bolt kits must be ordered separately.

Example:

- One (1) DG4S4-012C-U-B-60 valve
- One (1) 710775 solenoid plug connector, black, marked B
- One (1) 710776 solenoid plug connector, gray, marked A
- One (1) DGSM-01-20 T8 subplate
- One (1) BKDG01-633 bolt kit

Maximum recommended mounting bolt torque is 12,6 N.m (112 lbf. in.). Mounting bolts, when provided by customer, should be SAE grade 7 or better.

Products we offer:

- Cartridge valves
- DCV directional control valves
- Electric converters
- Electric machines
- Electric motors
- Gear motors
- Gear pumps
- Hydraulic integrated circuits (HICs)
- Hydrostatic motors
- Hydrostatic pumps
- Orbital motors
- PLUS+1® controllers
- PLUS+1® displays
- PLUS+1® joysticks and pedals
- PLUS+1® operator interfaces
- PLUS+1® sensors
- PLUS+1® software
- PLUS+1® software services, support and training
- Position controls and sensors
- PVG proportional valves
- Steering components and systems
- Telematics

Danfoss Power Solutions is a global manufacturer and supplier of high-quality hydraulic and electric components. We specialize in providing state-of-the-art technology and solutions that excel in the harsh operating conditions of the mobile off-highway market as well as the marine sector. Building on our extensive applications expertise, we work closely with you to ensure exceptional performance for a broad range of applications. We help you and other customers around the world speed up system development, reduce costs and bring vehicles and vessels to market faster.

Danfoss Power Solutions – your strongest partner in mobile hydraulics and mobile electrification.

Go to www.danfoss.com for further product information.

We offer you expert worldwide support for ensuring the best possible solutions for outstanding performance. And with an extensive network of Global Service Partners, we also provide you with comprehensive global service for all of our components.

Local address:

Hydro-Gear

www.hydro-gear.com

Daikin-Sauer-Danfoss

www.daikin-sauer-danfoss.com

**Danfoss
Power Solutions (US) Company**
2800 East 13th Street
Ames, IA 50010, USA
Phone: +1 515 239 6000

**Danfoss
Power Solutions GmbH & Co. OHG**
Krokamp 35
D-24539 Neumünster, Germany
Phone: +49 4321 871 0

**Danfoss
Power Solutions ApS**
Nordborgvej 81
DK-6430 Nordborg, Denmark
Phone: +45 7488 2222

**Danfoss
Power Solutions Trading
(Shanghai) Co., Ltd.**
Building #22, No. 1000 Jin Hai Rd
Jin Qiao, Pudong New District
Shanghai, China 201206
Phone: +86 21 2080 6201