

Vickers®

Vane Pumps



Overhaul Manual

Single Stage Single and Double Vane Pumps

V104, 124, 134, 144
V105, 125, 135, 145
V108, 128, 138, 148

V109, 129, 139, 149
V35*, 36*, 45*, 46*
(V)VF-**-**, (V)VG-**-**

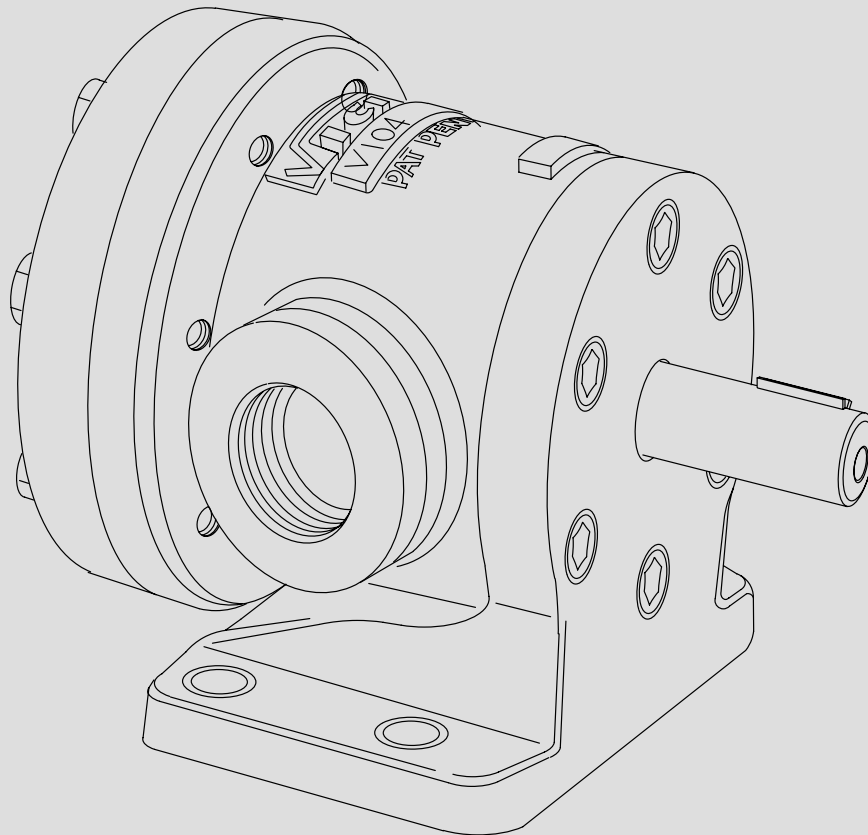

VICKERS

Reprinted 12/1/86

I-3100-S

Table of Contents

Section	Page
I. Operating Characteristics	4
Single Pump Series – Single Stage	4
Double Pump Series – Single Stage – Small Series Combination	4
– Single Stage – Intermediate and Small Series	5
– Single Stage – Large and Small Series Combinations	5
– Single Stage – Large and Intermediate Series Combinations	6
II. Description	6
III. Principles of Operation	6
A. Operation	6
B. Lubrication	6
C. Routine Inspection and Maintenance	7
IV. Overhaul	7
A. General	7
B. Disassembly	7
C. Reassembly	7
D. Product Life	7
V. Cartridge Assembly and Installation	8
A. Cartridge Assembly	8
B. Installation	8
C. Head Screw Adjustment	8
VI. Troubleshooting	9
VII. Parts & Illustration Drawings	10

Section I – Operating Characteristics

Type Balanced Vane, Fixed Delivery
 Series Single and Double, Single Stage
 Operating Pressure See Performance Data
 Input Speed, RPM See Performance Data
 Operating Fluid 150 S.S.U. at 100° F
 Mounting Face, Foot, Flange, Electric Motor End Bell
 Connections Pipe Thread Body Ports or Flanges

Performance data is based on input speed at 1200 rpm, pumping petroleum base fluid at 120° F. Minimum recommended drive speed for all series is 600 rpm. Characteristics at other drive speeds are approximately proportional to rpm. For performance data when using other than petroleum base fluids, see applicable installation drawing, shown on page 8.

Single Pump Series - Single Stage

Head Bolt Torque in lbf. in. Minimum	Model Numbers		Recommended Drive Speed maximum rpm	Delivery, gpm at 1200 r.p.m.			Horsepower Input at 1200 r.p.m.		
	Foot Mounting	Flange Mounting		0 psi	500 psi	1000 psi	0 psi	500 psi	1000 psi
Small Series 50 lbf. in.	V-104-Y-10	V-105-Y-10	1800	1.8	1.5	1.1	.20	0.9	1.5
	V-104-E-10	V-105-E-10	1800	2.7	2.4	2.0	.25	1.2	2.2
	V-104-G-10	V-105-G-10	1800	3.7	3.4	3.0	.25	1.4	2.6
	V-104-A-10	V-105-A-10	1800	5.3	5.0	4.7	.30	1.9	3.6
	V-104-C-10	V-105-C-10	1500	8.2	7.9	7.5	.35	2.8	5.2
	V-104-D-10	V-105-D-10	1200	11.5	11.0	10.6	.40	3.7	7.0
Intermediate Series 150 lbf. in.	V-124-20	V-125-20	1500	15.4	14.5	13.6	.70	5.8	10.9
	V-134-20	V-135-20	1500	19.5	18.8	18.0	.75	6.7	12.4
	V-134-U-20	V-135-U-20	1500	23.0	22.2	21.3	.80	8.1	14.9
	V-134-X-20	V-135-X-20	1200	29.9	28.9	27.8	1.00	9.7	18.8
	V-144-20	V-145-20	1200	37.9	.5	35.0	1.20	13.5	24.1
Large Series 150 lbf. in.	VF-40-10	VG-40-10	1200	41.7	39.5	37.2	1.60	14.0	26.5
	V-360-10	V-361-10	1200	48.5	46.8	45.0	2.00	16.5	31.5
	V-460-10	V-461-10	1200	60.6	58.3	56.0	2.70	20.4	38.4

Double Pump Series – Single Stage – Small Series Combination

Model Numbers		Small Volume - Head End Pump						Large Volume - Shaft End Pump					
		Delivery, gpm			Horsepower Input			Delivery, gpm			Horsepower Input		
Foot Mounting	Flange Mounting	0 psi	500 psi	1000 psi	0 psi	500 psi	1000 psi	0 psi	500 psi	1000 psi	0 psi	500 psi	1000 psi
V-108-YY-10	V-109-YY-10	1.8	1.5	1.1	.20	0.9	1.5	1.8	1.5	1.1	.20	0.9	1.5
V-108-YE-10	V-109-YE-10							2.7	2.4	2.0	.25	1.2	2.2
V-108-YG-10	V-109-YG-10							3.7	3.4	3.0	.25	1.4	2.6
V-108-YA-10	V-109-YA-10							5.3	5.0	4.7	.30	1.9	3.6
V-108-YC-10	V-109-YC-10							8.2	7.9	7.5	.35	2.8	5.2
V-108-YD-10	V-109-YD-10							11.5	11.0	10.6	.40	3.7	7.0
V-108-EE-10	V-109-EE-10	2.7	2.4	2.0	.25	1.2	2.2	2.7	2.4	2.0	.25	1.2	2.2
V-108-EG-10	V-109-EG-10							3.7	3.4	3.0	.25	1.4	2.6
V-108-EA-10	V-109-EA-10							5.3	5.0	4.7	.30	1.9	3.6
V-108-EC-10	V-109-EC-10							8.2	7.9	7.5	.35	2.8	5.2
V-108-ED-10	V-109-ED-10							11.5	11.0	10.6	.40	3.7	7.0
V-108-GG-10	V-109-GG-10							3.7	3.4	3.0	.25	1.4	2.6
V-108-GA-10	V-109-GA-10	3.7	3.4	3.0	.25	1.4	2.6	5.3	5.0	4.7	.30	1.9	3.6
V-108-GC-10	V-109-GC-10							8.2	7.9	7.5	.35	2.8	5.2
V-108-GD-10	V-109-GD-10							11.5	11.0	10.6	.40	3.7	7.0
V-108-AA-10	V-109-AA-10							5.3	5.0	4.7	.30	1.9	3.6
V-108-AC-10	V-109-AC-10	5.3	5.0	4.7	.30	1.9	3.6	8.2	7.9	7.5	.35	2.8	5.2
V-108-AD-10	V-109-AD-10							11.5	11.0	10.6	.40	3.7	7.0
V-108-CC-10	V-109-CC-10							8.2	7.9	7.5	.35	2.8	5.2
V-108-CD-10	V-109-CD-10	8.2	7.9	7.5	.35	2.8	5.2	11.5	11.0	10.6	.40	3.7	7.0
V-108-DD-10	V-109-DD-10							11.5	11.0	10.6	.40	3.7	7.0

Double Pump Series – Single Stage – Intermediate and Small Series Combination

Model Numbers		Small Volume - Head End Pump						Large Volume - Shaft End Pump					
		Delivery, gpm			Horsepower Input			Delivery, gpm			Horsepower Input		
Foot Mounting	Flange Mounting	0 psi	500 psi	1000 psi	0 psi	500 psi	1000 psi	0 psi	500 psi	1000 psi	0 psi	500 psi	1000 psi
V-128-Y-20	V-129-Y-20	1.8	1.5	1.1	.20	0.9	1.5	15.4	14.5	13.6	.70	5.8	10.9
V-128-E-20	V-129-E-20	2.7	2.4	2.0	.25	1.2	2.2						
V-128-G-20	V-129-G-20	3.7	3.4	3.0	.25	1.4	2.6						
V-128-A-20	V-129-A-20	5.3	5.0	4.7	.30	1.9	3.6						
V-128-C-20	V-129-C-20	8.2	7.9	7.5	.35	2.8	5.2						
V-128-D-20	V-129-D-20	11.5	11.0	10.6	.40	3.7	7.0						
V-138-Y-20	V-139-Y-20	1.8	1.5	1.1	.20	0.9	1.5	19.5	18.8	18.0	.75	6.7	12.4
V-138-E-20	V-139-E-20	2.7	2.4	2.0	.25	1.2	2.2						
V-138-G-20	V-139-G-20	3.7	3.4	3.0	.25	1.4	2.6						
V-138-A-20	V-139-A-20	5.3	5.0	4.7	.30	1.9	3.6						
V-138-C-20	V-139-C-20	8.2	7.9	7.5	.35	2.8	5.2						
V-138-D-20	V-139-D-20	11.5	11.0	10.6	.40	3.7	7.0						
V-138U-Y-20	V-139U-Y-20	1.8	1.5	1.1	.20	0.9	1.5	23.0	22.2	21.3	.80	8.1	14.9
V-138U-E-20	V-139U-E-20	2.7	2.4	2.0	.25	1.2	2.2						
V-138U-G-20	V-139U-G-20	3.7	3.4	3.0	.25	1.4	2.6						
V-138U-A-20	V-139U-A-20	5.3	5.0	4.7	.30	1.9	3.6						
V-138U-C-20	V-139U-C-20	8.2	7.9	7.5	.35	2.8	5.2						
V-138U-D-20	V-139U-D-20	11.5	11.0	10.6	.40	3.7	7.0						
V-138X-Y-20	V-139X-Y-20	1.8	1.5	1.1	.20	0.9	1.5	29.9	28.9	27.8	1.00	9.7	18.8
V-138X-E-20	V-139X-E-20	2.7	2.4	2.0	.25	1.2	2.2						
V-138X-G-20	V-139X-G-20	3.7	3.4	3.0	.25	1.4	2.6						
V-138X-A-20	V-139X-A-20	5.3	5.0	4.7	.30	1.9	3.6						
V-138X-C-20	V-139X-C-20	8.2	7.9	7.5	.35	2.8	5.2						
V-138X-D-20	V-139X-D-20	11.5	11.0	10.6	.40	3.7	7.0						
V-148-Y-20	V-149-Y-20	1.8	1.5	1.1	.20	0.9	1.5	37.9	36.5	35.0	1.20	13.5	24.1
V-148-E-20	V-149-E-20	2.7	2.4	2.0	.25	1.2	2.2						
V-148-G-20	V-149-G-20	3.7	3.4	3.0	.25	1.4	2.6						
V-148-A-20	V-149-A-20	5.3	5.0	4.7	.30	1.9	3.6						
V-148-C-20	V-149-C-20	8.2	7.9	7.5	.35	2.8	5.2						
V-148-D-20	V-149-D-20	11.5	11.0	10.6	.40	3.7	7.0						

Double Pump Series – Single Stage – Large and Small Series Combination

Model Numbers		Small Volume - Head End Pump						Large Volume - Shaft End Pump					
		Delivery, gpm			Horsepower Input			Delivery, gpm			Horsepower Input		
Foot Mounting	Flange Mounting	0 psi	500 psi	1000 psi	0 psi	500 psi	1000 psi	0 psi	500 psi	1000 psi	0 psi	500 psi	1000 psi
VVF-1-40	VVG-1-40	1.8	1.5	1.1	.20	0.9	1.5	41.7	39.5	37.2	1.6	14.0	26.5
VVF-2-40	VVG-2-40	2.7	2.4	2.0	.25	1.2	2.2						
VVF-3-40	VVG-3-40	3.7	3.4	3.0	.25	1.4	2.6						
VVF-5-40	VVG-5-40	5.3	5.0	4.7	.30	1.9	3.6						
VVF-8-40	VVG-8-40	8.2	7.9	7.5	.35	2.8	5.2						
VVF-11-40	VVG-11-40	11.5	11.0	10.6	.40	3.7	7.0						
V-368-Y	V-369-Y	1.8	1.5	1.1	.20	0.9	1.5	48.5	46.8	45.0	2.0	16.5	31.5
V-368-E	V-369-E	2.7	2.4	2.0	.25	1.2	2.2						
V-368-G	V-369-G	3.7	3.4	3.0	.25	1.4	2.6						
V-368-A	V-369-A	5.3	5.0	4.7	.30	1.9	3.6						
V-368-C	V-369-C	8.2	7.9	7.5	.35	2.8	5.2						
V-368-D	V-369-D	11.5	11.0	10.6	.40	3.7	7.0						
V-468-Y	V-469-Y	1.8	1.5	1.1	.20	0.9	1.5	60.6	58.3	56.0	2.7	20.4	38.4
V-468-E	V-469-E	2.7	2.4	2.0	.25	1.2	2.2						
V-468-G	V-469-G	3.7	3.4	3.0	.25	1.4	2.6						
V-468-A	V-469-A	5.3	5.0	4.7	.30	1.9	3.6						
V-468-C	V-469-C	8.2	7.9	7.5	.35	2.8	5.2						
V-468-D	V-469-D	11.5	11.0	10.6	.40	3.7	7.0						

Double Pump Series - Single Stage – Large and Intermediate Series Combination

Model Numbers		Small Volume - Head End Pump						Large Volume - Shaft End Pump					
		Delivery, gpm			Horsepower Input			Delivery, gpm			Horsepower Input		
Foot Mounting	Flange Mounting	0 psi	500 psi	1000 psi	0 psi	500 psi	1000 psi	0 psi	500 psi	1000 psi	0 psi	500 psi	1000 psi
VVSF-14-40	VVSG-14-40	15.4	14.4	13.3	.70	5.8	10.9	41.7	39.5	37.2	1.6	14.0	26.5
VVSF-18-40	VVSG-18-40	19.4	18.3	17.1	.75	6.7	12.4						
VVSF-22-40	VVSG-22-40	22.9	21.9	20.8	.85	8.1	14.9						
VVSF-28-40	VVSG-28-40	29.9	28.8	27.6	1.00	9.7	18.8						
VVSF-36-40	VVSG-36-40	37.8	35.9	33.9	1.20	13.5	24.1						
VVSF-14-48	VVSG-14-48	15.4	14.4	13.3	.70	5.8	10.9	48.5	46.8	45.0	2.0	16.5	31.5
V-350-FT	V-350-FL	19.4	18.3	17.1	.75	6.7	12.4						
VVSF-22-48	VVSG-22-48	22.9	21.9	20.8	.85	8.1	14.9						
V-353-FT	V-353-FL	29.9	28.8	27.6	1.00	9.7	18.8						
V-356-FT	V-356-FL	37.8	35.9	33.9	1.20	13.5	24.1						
VVSF-14-60	VVSG-14-60	15.4	14.4	13.3	.70	5.8	10.9	60.6	58.3	56.0	2.7	2.0	38.4
V-450-FT	V-450-FL	19.4	18.3	17.1	.75	6.7	12.4						
VVSF-22-60	VVSG-22-60	22.9	21.9	20.8	.85	8.1	14.9						
V-453-FT	V-453-FL	29.9	28.8	27.6	1.00	9.7	18.8						
V-456-FT	V-456-FL	37.8	35.9	33.9	1.20	13.5	24.1						

Section II – Description

This manual contains service and maintenance information for Vickers single and double pumps. These hydraulically balanced cartridge type vane pumps are used to provide a constant supply of hydraulic fluid under pressure and are produced in three basic housing sizes: small, intermediate and large. Cartridges of different displacement may be used interchangeably in each series. These pumps can be used as single units or two may be assembled on a common drive shaft (double pump) providing an almost infinite number of combinations. Figure 1 illustrates a cross sectional view of a flange mounting, small and intermediate series combination double pump, assembled for left hand rotation.

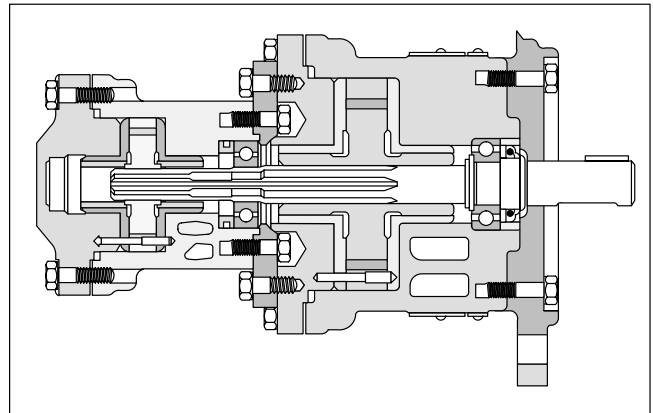

Figure 1.

Section III – Principles of Operation

A. Operation

Pumping is performed by cartridges consisting of a ring, rotor, two bushings, twelve vanes and a locating pin or screws (see Figure 2). The splined pump shaft rotates driving a slotted rotor. Vanes within the rotor slots are thrown out by centrifugal force and held out by system pressure to follow a double lobed cam ring. Movement of the vanes in and out as they follow the cam causes the chambers between them to increase in size and pick up fluid from the reservoir as the vanes cross the inlet porting. Chamber size decreases when the vanes cross the outlet porting forcing fluid out into the system.

The size of the cartridge ring determines the pump displacement. Ring change alters delivery. However, the 11

gpm ring in the small series and the 36 gpm ring in the intermediate series are used with wide vanes and rotor so conversions to these capacities require additional change of rotor, vanes and head.

B. Lubrication

None is required for current design models. Older designs require lubrication of the front shaft bearing. A grease fitting is provided on top of the pump body. (Some of the larger pumps also incorporate a grease relief fitting on the bottom of the body.) It is recommended that these fittings be lubricated sparingly (approximately one tablespoonful every six months) with a low pressure gun using a good quality, high temperature, bearing grease.



CAUTION

Over-lubrication can damage the shaft seal.

C. Routine Inspection and Maintenance

1. Make certain all hydraulic connections are tight to prevent fluid leakage or entry of air into the system. Complete overhaul may be accomplished by means of cartridge and gasket kits.

2. Check fluid level in the reservoir to assure an adequate supply to the pump intake. When adding fluid, always pour it through a 200 mesh or finer screen.

3. Inspect the filter element and replace if dirty.
4. Inspect the fluid for contamination. If contaminated, drain the system and thoroughly clean the reservoir. Change the filters and flush the complete system with new fluid. Again drain the system and refill with new fluid.
5. Check the reservoir air breather and replace if dirty.

D. Product Life

The longevity of these products is dependent upon environment, duty cycle, operating parameters and system cleanliness. Since these parameters vary from application to application, the ultimate user must determine and establish the periodic maintenance required to maximize life and detect potential component failure.

Section IV – Overhaul

A. General

Complete overhaul may be accomplished by means of cartridge and gasket kits.

B. Disassembly

Disassembly may be accomplished in the order shown in the illustration (Figures 3 or 4).



WARNING

Before breaking a circuit connection, make certain that power is off and system pressure has been released. Lower all vertical cylinders, discharge accumulators, and block any load whose movement could generate pressure.

Prepare a clean, lint-free surface on which to lay internal parts of the pump. Thoroughly clean areas adjacent to the components being removed to minimize possibility of dirt entering the system. Cap or cover all exposed ports and openings into the system.

Inspect and replace as follows:

1. Vanes, for wear and sticking in rotor slots. Vanes must move in slots from their own weight when dry. Replace if defective. Stone new vanes lightly on an India stone to remove sharp edges.

2. Ring, for scored or cross-grooved cam face. Replace if grooved or scored.

3. Faces of rotor and bushings for wear and scoring. Remove light scores by lapping; replace if heavily scored. Stone new parts lightly to remove burrs.

4. Bearings for cracked or pitted races or pitted balls. Replace if defective.

5. Shaft for wear at seal lip journal. Replace if scored.

6. Replace shaft seal, O-ring and head packing at each teardown.

C. Reassembly

Assemble parts in reverse order of disassembly, noting the following:

1. Assembly seals with spring toward inside of the pump.

2. Coat all parts with compatible fluid and lightly lubricate the lip of the shaft seal to prevent damage during installation.

3. Install bearing and snap ring on shaft end and place in the body.

4. Spring in the shaft seal must be toward the shaft bearing.

5. Install cartridge parts so arrows on the parts are pointed for intended rotation as viewed from the shaft end.

6. Assemble the pin so its small diameter end fits into the body for right hand rotation (large end in body for left hand rotation). See installation page 5.

Section V – Cartridge Assembly and Installation

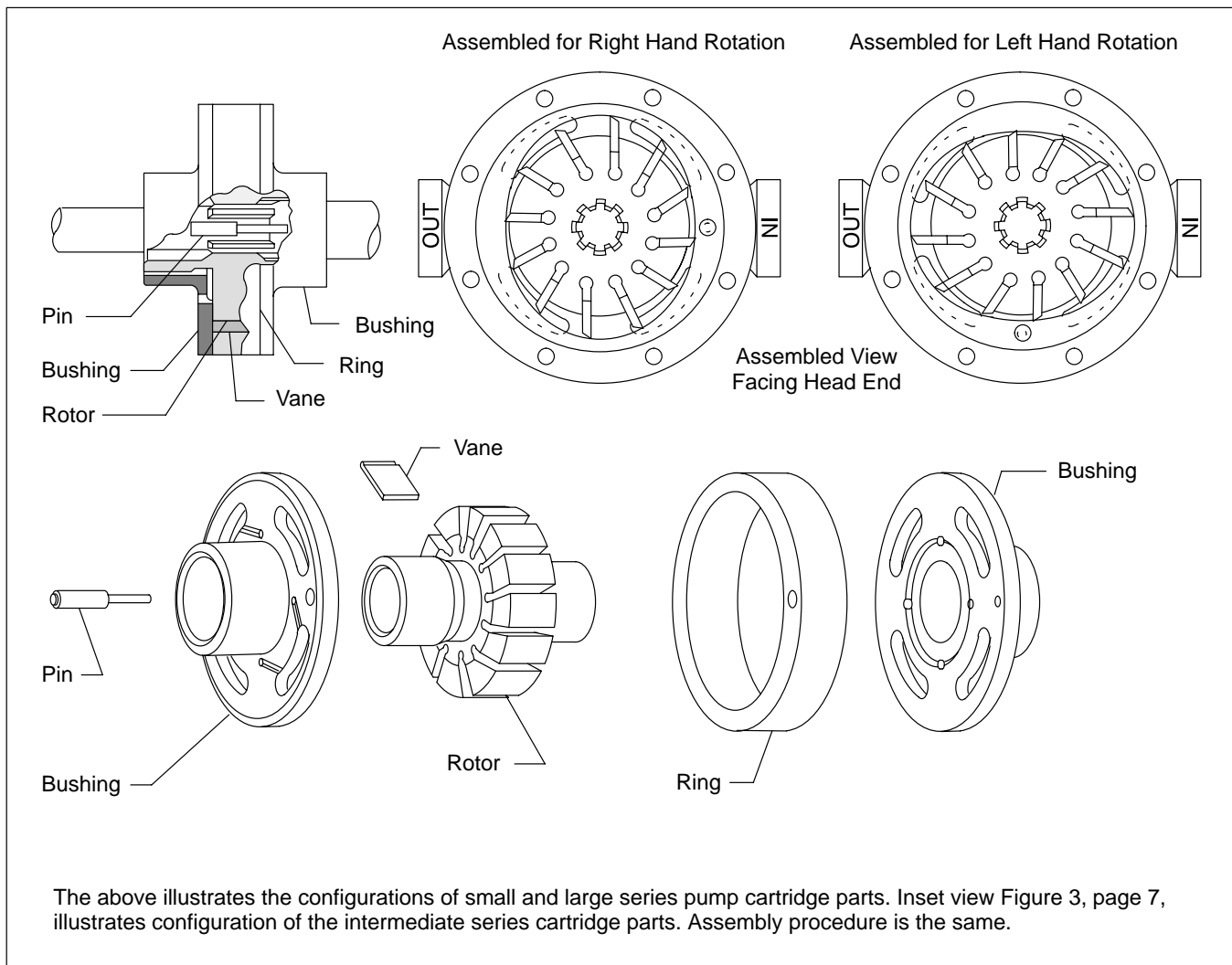

Figure 2.

A. Cartridge Assembly

Figure 2 illustrates a typical cartridge assembly and installation, when viewed from the head end. The cartridge assembly procedure is the same for both single and double pumps, depending on the direction of shaft rotation.

The stepped diameter locating pin prevents improper assembly of the cartridge. However, caution must be exercised to install the cartridge properly for the direction of rotation desired.

The large series pump cartridges have a locating screw and a retaining screw in lieu of the locating pin used in the small and intermediate series.

NOTE

The direction of rotation (right hand or left hand) is always determined by viewing the pump from the shaft end.

B. Installation

Right Hand Rotation: Insert the small end of the located pin into the small hole in the pump body at a 3 o'clock position.

Left Hand Rotation: Insert the large end of the located pin into the large hole in the pump body at a 6 o'clock position.

C. Head Screw Adjustment

Some pump cover heads and intermediate heads (double pumps) are provided with two small holes to match the two diameters of the locating pin. Install the head so the pin fits the hole size to prevent the pin from bending or shearing when the pump is put into operation.

Pull the head down gradually, alternately tightening the screws 180° from each other until the head seats evenly on the bushing. Turn the shaft by hand during the process until a light, smooth snugness is felt through a complete revolution. Do not over-tighten the screws, causing the shaft to bind.

Before starting these pumps, check for freedom of movement of the internal parts by turning the shaft by hand. Never start a pump which shows evidence of binding.



CAUTION

A new or overhauled pump must be started under load on the first run. This will create a back pressure to assure adequate internal lubrication. After a pump is broken in, it can be started under "no-load" conditions.

Start the pump by "jogging" the drive motor a few times to be sure the pump is primed.

If the pump is new or has been overhauled, be certain it is properly installed. Check the direction of shaft rotation and alignment of the shaft with the drive motor. Since it is difficult to achieve perfect shaft alignment, a flexible coupling must be used.

Exercise care with pumps driven by belts, chain drives, spur gears, etc. to prevent excessive side loading of the drive shaft. Consult your Vickers' representative for recommendations on these type drives.

Pump life will be shortened by operation beyond maximum pressure and speed ratings. Since these units are positive displacement, a relief valve must be used to limit maximum system pressure to recommended limits.

Section VI – Troubleshooting

TROUBLE	PROBABLE CAUSE	REMEDY
Pump not delivering fluid	<p>Pump driven in wrong direction of rotation</p> <p>Pump drive shaft broken or shaft key sheared (direct drive)</p> <p>Fluid intake pipe in reservoir blocked or oil viscosity too heavy to pick up prime Viscosity should not exceed 4000 S.S.U.</p> <p>Air leaks at intake Pump not priming Oil level too low</p> <p>Vane or vanes stuck in rotor slots</p>	<p>Must be reversed immediately to prevent seizure. Check direction of drive rotation against proper pump rotation as indicated by arrow on body.</p> <p>Remove pump from accessory mounting pad and determine damage to pump cartridge. Replace needed parts.</p> <p>Drain complete system. Add new fluid of proper viscosity. Filter the new fluid as recommended. Check all filters for dirt and sludge.</p> <p>Check intake connection for air leak. Tighten securely.</p> <p>Loosen connection in outlet line. Bleed-off air until fluid flows.</p> <p>The fluid level must be above intake opening in intake pipe. Check minimum drive speed which may be too slow to prime the pumps. Inspect rotor slots for wedged chips or foreign particles and replace all damaged parts. Flush complete system thoroughly by recommended processes and fill system with new, clean hydraulic fluid.</p>
Pump making noise	<p>Partially clogged intake strainer or restricted intake pipe</p> <p>Defective bearing Air leak at pump intake piping joints or pump shaft seal</p> <p>Coupling misalignment</p>	<p>Pump must receive intake fluid freely or cavitation will result. Drain system, clean intake pipe, and clean or replace strainer. Add new fluid and strain by recommended procedures.</p> <p>Disassemble pump and replace bearing. Test by pouring oil on joints and around drive shaft. Listen for change in operation. Tighten joints affected. Check pump shaft oil seal for leakage and replace if necessary, in accordance with instructions outlined in this manual. Check shaft for scoring at seal contact area and replace shaft if grooving is evident.</p> <p>Check shaft bearing and seal for possible damage. Replace if necessary. Re-align shafts.</p>

Table 1. Troubleshooting Chart

Section VII – Parts & Illustration Drawings

The intermediate series, current design, cartridge parts are shown in the lower inset view. These modified parts provide better inlet conditions by reducing wear and excessive noise

due to cavitation. Thus permitting heavier viscosity fluids to be used while improving overall pumps performance.

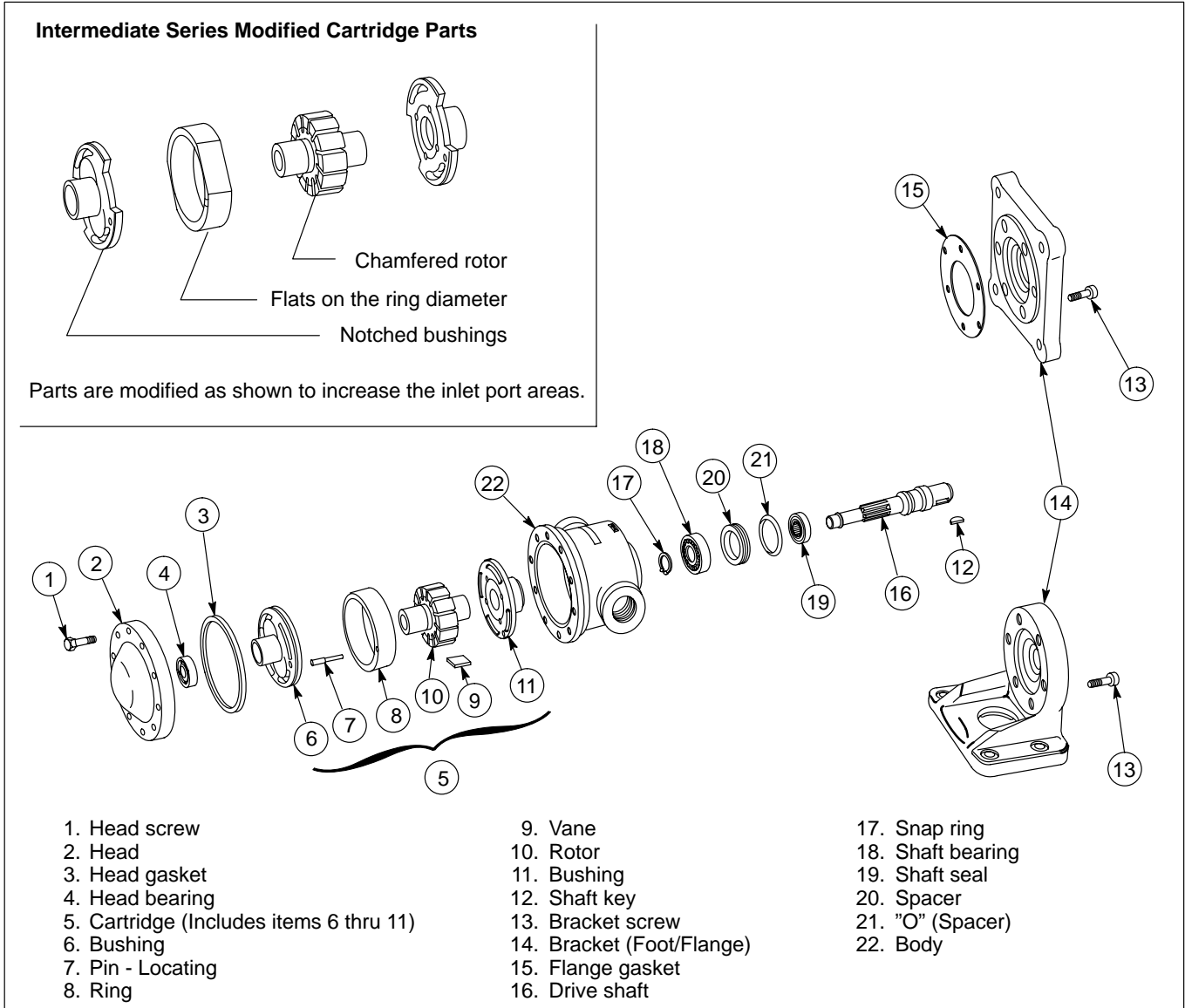

Single Pumps		
Pump Size	Service Parts Drawings	Installation Drawings
Small Series	I-3101-S	I-138094
Intermediate Series	I-1630-S	I-133744
Large Series	I-1695-S	I-138005
Double Pumps		
Small Series Combination	I-1801-S	I-136638
Intermediate and Small Series Combination	I-1696-S	I-135250
Large and Small Series Combination	I-1800-S	I-137475
Large and Intermediate Series Combination	I-1697-S	I-133501

Typical Single Pump Parts & Illustration Drawing

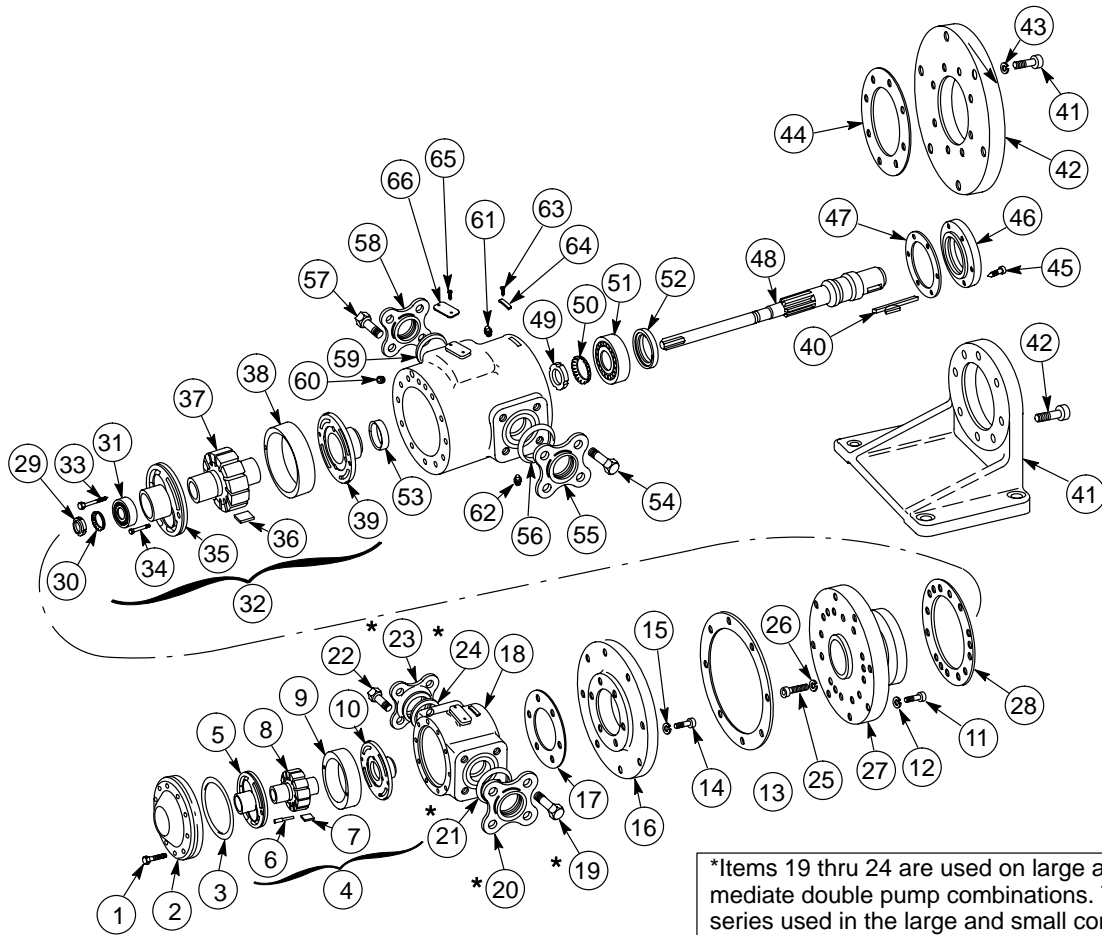

*Items 19 thru 24 are used on large and intermediate double pump combinations. The small series used in the large and small combinations have female pipe threaded ports in the body.

- | | | | |
|----------------------------|-----------------------------|---------------------|-----------------------------|
| 1. Head screw | 18. Body | 35. Bushing | 52. Shaft seal |
| 2. Head | *19. Flange screw | 36. Vane | 53. Seal |
| 3. Head gasket | *20. Flange (inlet) | 37. Rotor | (used on basic design only) |
| 4. Cartridge | *21. Gasket (inlet) | 38. Ring | 54. Flange screw |
| (Includes items 5 thru 10) | *22. Flange screw | 39. Bushing | 55. Flange (Inlet) |
| 5. Bushing | *23. Flange (outlet) | 40. Shaft key | 56. Gasket (inlet) |
| 6. Pin - locating | *24. Gasket (outlet) | 41. Bracket screw | 57. Flange screw |
| 7. Vane | 25. Head screw | 42. Bracket | 58. Flange (outlet) |
| 8. Rotor | 26. Lockwasher | (Foot/Flange) | 59. Gasket (outlet) |
| 9. Ring | 27. Head (intermediate) | 43. Lockwasher | 60. Plug |
| 10. Bushing | 28. Gasket | 44. Flange gasket | 61. Grease fitting |
| 11. Screw | 29. Nut | 45. Retainer screw | (used on basic design only) |
| 12. Lockwasher | 30. Lockwasher | 46. Retainer | 62. Grease relief fitting |
| 13. Gasket | 31. Bearing | 47. Retainer gasket | (used on basic design only) |
| 14. Screw | 32. Cartridge | 48. Drive shaft | 63. Screw |
| 15. Lockwasher | (includes items 33 thru 39) | 49. Lock nut | 64. Rotating plate |
| 16. Mounting Flange | 33. Locating screw | 50. Lockwasher | 65. Screw |
| 17. Gasket | 34. Retaining screw | 51. Bearing | 66. Name plate |

Typical Double Pump Parts & Illustration Drawing

Eaton Hydraulics

15151 Highway 5
Eden Prairie, MN 55344
Telephone: 612 937-7254
Fax: 612 937-7130
www.eatonhydraulics.com

46 New Lane, Havant
Hampshire PO9 2NB
England
Telephone: (44) 170-548-6451
Fax: (44) 170-548-7110

